

6 TUSCAN CAST STONE HEADER AT STEEL FRAMING DETAIL
Scale: N.T.S.

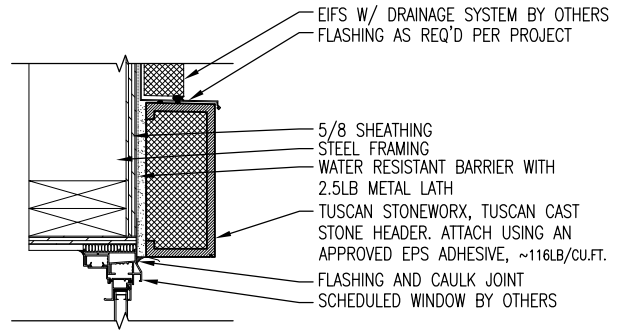

3 TUSCAN CAST STONE HEADER AT WOOD FRAMING DETAIL
Scale: N.T.S.

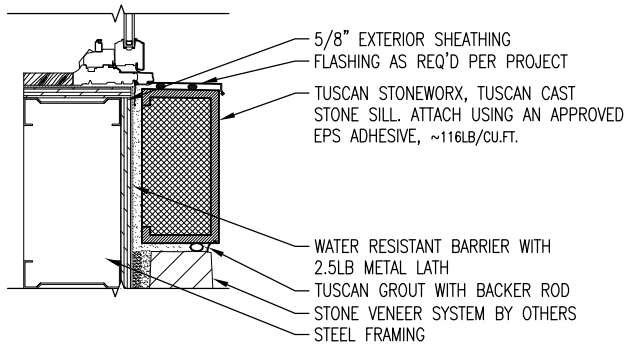

5 TUSCAN CAST STONE SILL AT STEEL FRAMING DETAIL
Scale: N.T.S.

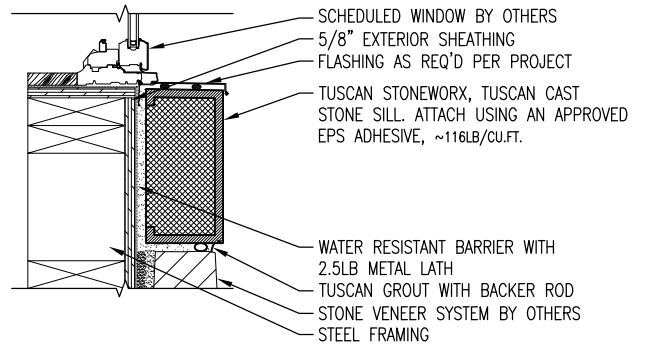

2 TUSCAN CAST STONE SILL AT WOOD FRAMING DETAIL
Scale: N.T.S.

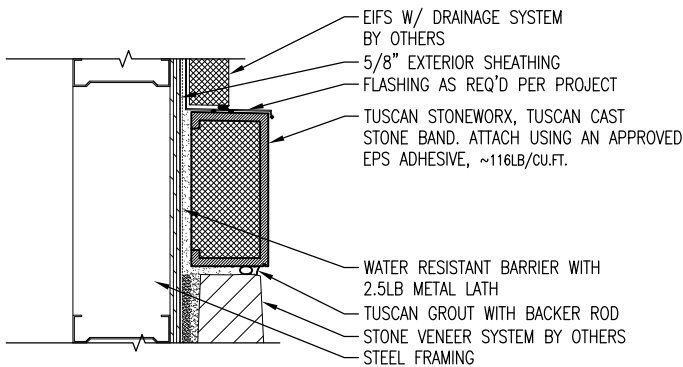

4 TUSCAN CAST STONE BAND AT STEEL FRAMING DETAIL
Scale: N.T.S.

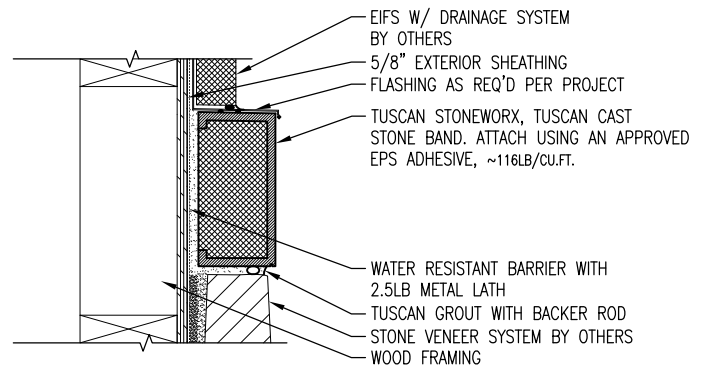

1 TUSCAN CAST STONE BAND AT WOOD FRAMING DETAIL
Scale: N.T.S.

I:\Tuscan Cast Stone\01-Clients\Tuscan StoneWorx\Details\Detail-1.dwg

The architecture, engineering and design of the project using Tuscan StoneWorx is the responsibility of the project's design professional. Tuscan StoneWorx is a cast product that derives from natural stone, leaving a certain degree of color variance beyond our control. All systems must comply with state and local building codes and standards. This drawing is for preproduction approval and is not intended for production of parts, thus Tuscan StoneWorx disclaims any liability for the approval of this drawing and for the architecture, design, engineering or workmanship of any project.

Tuscan Cast Stone Details

DATE: 02/24/2010

SCALE: AS NOTED

DRAWN BY: C. HAWS

SHEET #: 1



165 N. 1330 W. Ste. C-4 Orem, Utah 84057
P: (888) 368-9494 F: (801) 734-6815
WWW.TUSCANSTONEWORX.COM

GENERAL NOTES:

1. TUSCAN CAST STONE PARTS WITH STACKED MASONRY MUST HAVE STEEL ANGLE ABOVE TO SUPPORT MASONRY. TUSCAN CAST STONE IS NOT STRUCTURAL.
2. TUSCAN CAST STONE PARTS WEIGH APPROXIMATELY 116LB/CU.FT.
3. SUBSTRATES:
 - 3.1. DENS GLASS GOLD / GLASS FIBER BOARD (EXT. DRYWALL).
 - 3.1.1. WITH THE USE OF LIQUID VAPOR BARRIER, METAL LATH IS NOT REQUIRED FOR ADHESION OF TUSCAN CAST.
 - 3.1.2. WITH THE USE OF PAPER WRAP, METAL LATH IS REQUIRED FOR ADHESION OF TUSCAN CAST.
 - 3.2. MASONRY WALLS.
 - 3.2.1. TUSCAN CAST STONE MAY BE ADHERED DIRECTLY TO THE WALL, IT IS OPTIONAL TO USE METAL LATH.
 - 3.3. PLYWOOD (EXT. SHEATHING).
 - 3.3.1. WITH THE USE OF A LIQUID VAPOR BARRIER, METAL LATH IS NOT REQUIRED FOR ADHESION OF TUSCAN CAST.
 - 3.3.2. WITH THE USE OF PAPER WRAP, METAL LATH IS REQUIRED FOR ADHESION OF TUSCAN CAST.
 - 3.4. EXISTING STUCCO/EIFS
 - 3.4.1. TUSCAN CAST STONE MAY BE ADHERED DIRECTLY TO THE SURFACE.

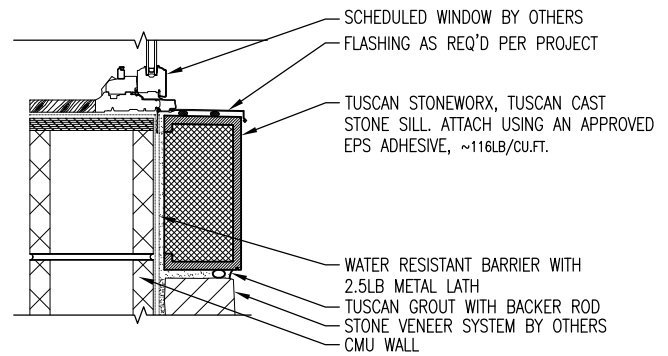

3 TUSCAN CAST STONE SILL AT CMU WALL DETAIL Scale: N.T.S.

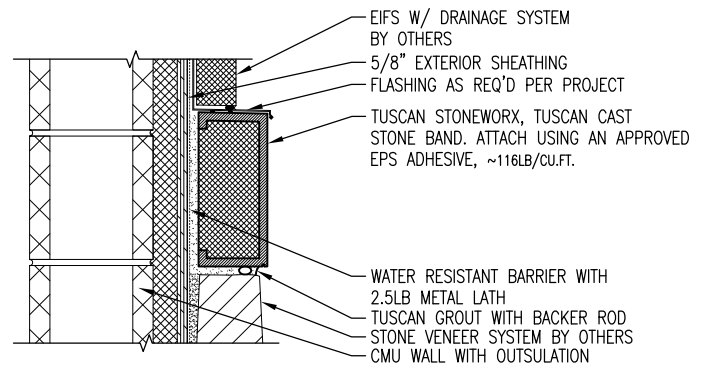

2 TUSCAN CAST STONE BAND AT CMU WITH OUTSULATION DETAIL Scale: N.T.S.

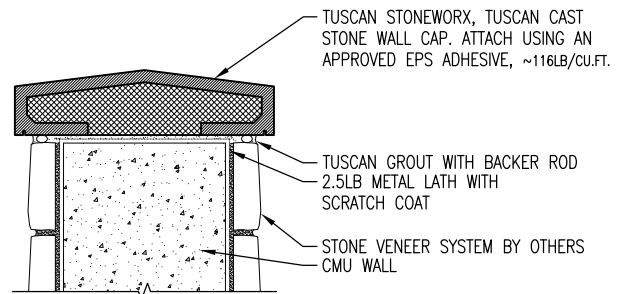

1 TUSCAN CAST STONE TYPICAL WALL CAP DETAIL Scale: N.T.S.

I:\Tuscan Cast Stone\01-Clients\Tuscan StoneWorx\Details\Detail-1.dwg

The architecture, engineering and design of the project using Tuscan StoneWorx is the responsibility of the project's design professional. Tuscan StoneWorx is a cast product that derives from natural stone, leaving a certain degree of color variance beyond our control. All systems must comply with state and local building codes and standards. This drawing is for preproduction approval and is not intended for production of parts, thus Tuscan StoneWorx disclaims any liability for the approval of this drawing and for the architecture, design, engineering or workmanship of any project.

Tuscan Cast Stone Details

DATE: 02/24/2010
SCALE: AS NOTED
DRAWN BY: C. HAWS
SHEET #: 2

TUSCAN STONEWORX
 165 N. 1330 W. Ste. C-4 Orem, Utah 84057
 P: (888) 368-9494 F: (801) 734-6815
 WWW.TUSCANSTONEWORX.COM